



COURSE CONSTRUCTION  
SPECIFICATIONS  
PRESENTED BY RHEINMETALL

Mission

JDG2020



**RHEINMETALL**  
DEFENCE

2020 Engineering Games  
Mission JDG 2020: Change de world  
**Course construction specifications**  
École de technologie supérieure

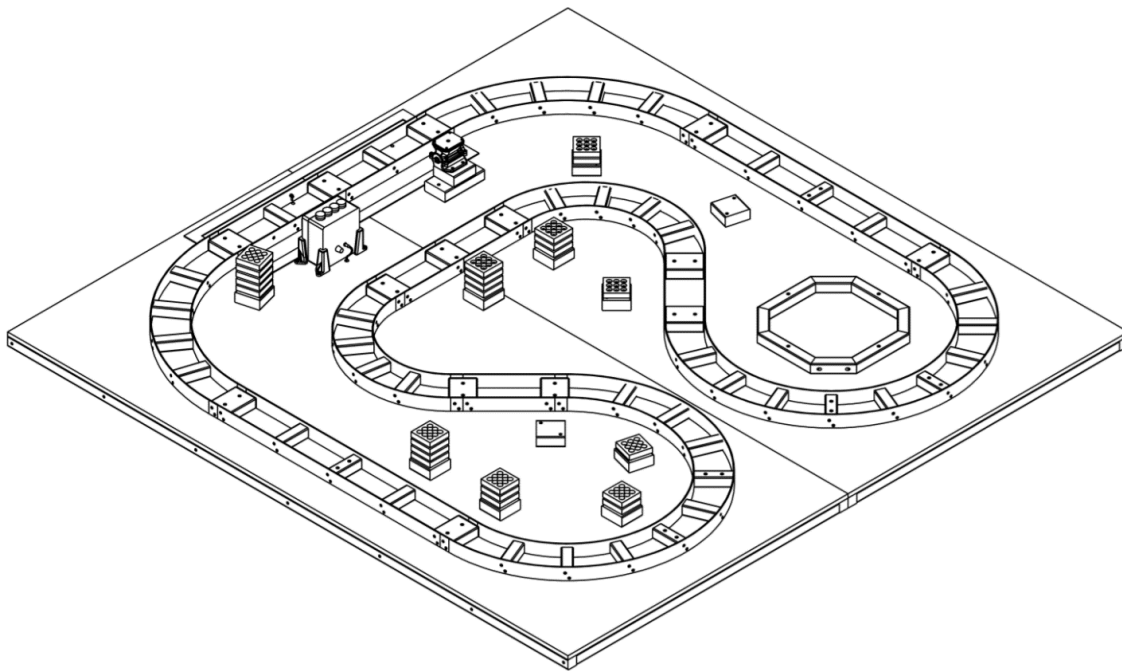

Design, drawings and redaction by:  
Alexandre Mongrain  
VP Machine:  
Gabriel Lévesque  
With:  
Pierrick Arsenault  
Ben Fevereiro



A HUGE thanks to all partners involved in the 2020 Engineering Games Machine challenge. Without you, it would be inconceivable to successfully carry out this ambitious project.

Machine's official sponsor



Machine's official supplier



Machine projects' mentor



RHEINMETALL DEFENCE MISSION JDG2020

# Table of contents

1. Rails.....	1
1.1. Building the links .....	1
1.2. Partial assembling.....	4
2. Course.....	8
2.1. Building the platform .....	8
2.2. Tracing the positioning.....	14
3. Challenge components.....	16
3.1. Packaging station .....	16
3.2. Making the trays.....	18
3.3. Tray stations.....	20
3.4. Dispenser .....	21
4. Final assembly .....	23
4.1. Rail installation.....	23
4.2. Installation of the challenge components.....	25
4.3. Electrical power supply .....	27



# 1. Rails

## 1.1. Building the links

### Required material

- (3x) 2"x2"x8' spruce
- (1x) 2"x4"x8' spruce
- Miter saw
- 1/8" drill bit
- 3/32" drill bit
- Drill
- Two Sharpie markers (red and blue)
- (4x) Provided drilling jig
- Measuring tape
- Optional: chamfer bit

### Making the 42 2"x2" links

- On the Miter saw, cut 42 lengths of 4-3/4" from the 2"x2" spruces.
  - The use of a stop on the miter saw is strongly recommended.
- Identify with an "X" a single long surface with a Sharpie (any color) on all pieces.
- Identify the two small surfaces using two different colors on all pieces.
  - The white jig will be associated with the red marked side, and the blue jig will be associated with the blue marked side.
- For each side, press the corresponding jig on its three bearing surfaces by pointing the arrow towards the surface identified by an "X" and drill in the holes with a 3/32" drill bit. Repeat for all pieces.
- For 6 of the 42 links, drill and chamfer (optionally) two 1/8" mounting holes on the surface of the "X" (the location is not critical).

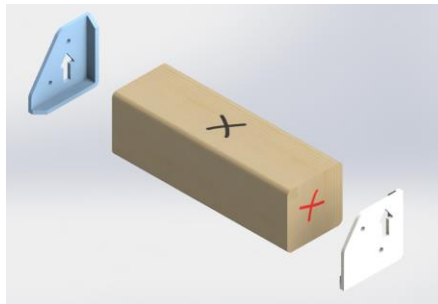

Figure 1: 2"x2" link render with marks and jigs



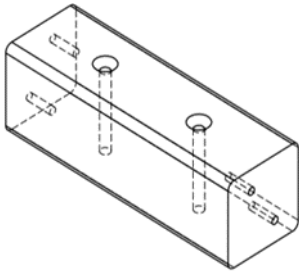

Figure 2: 2"x2" link isometric view

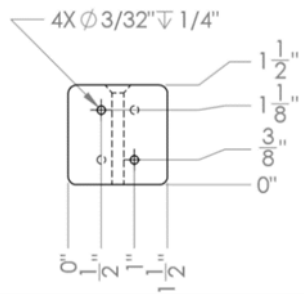

Figure 4: 2"x2" link side view

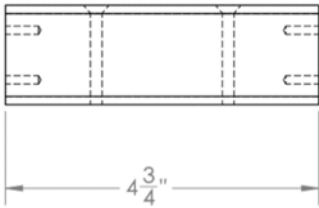

Figure 3: 2"x2" link face view

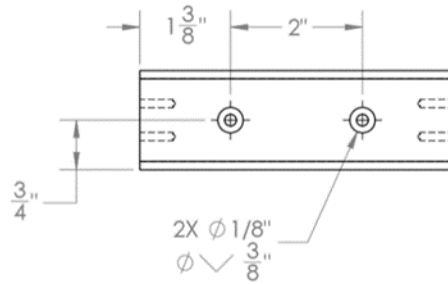

Figure 5: 2"x2" link top view





## Building the 14 2"x4" links

- On the miter saw, cut 14 lengths of 4-1/2" from the 2"x4" spruces.
  - The use of a stop on the miter saw is strongly recommended.
- Identify with an "X" a single long surface with a Sharpie (any color) on all cut pieces.
- Identify the two small surfaces of two different colors for all the pieces.
  - The white jig will be associated with the red marked side, and the blue jig will be associated with the blue marked side.
- For each side, press the corresponding jig on its three bearing surfaces by pointing the arrow towards the identified surface with an "X" and drill through the holes in the jig with a 3/32" drill bit. Repeat for all pieces.
- For all pieces, drill and chamfer (optionally) two 1/8" fixing holes on the surface of the "X" (the location is not critical).

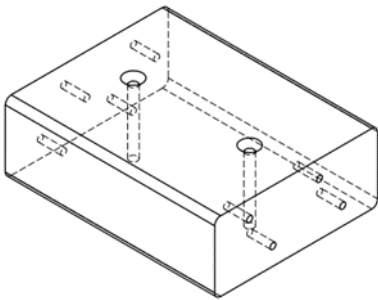

Figure 6: 2"x4" link isometric view

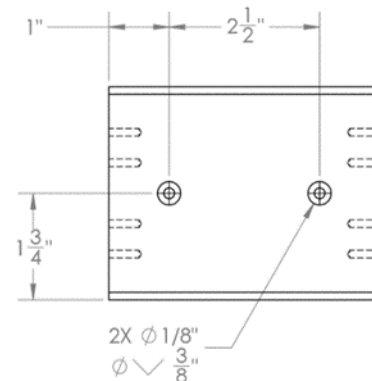

Figure 8: 2"x4" link top view

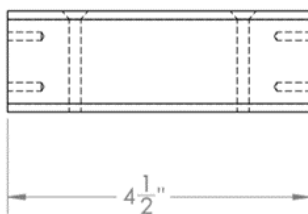

Figure 7: 2"x4" link face view

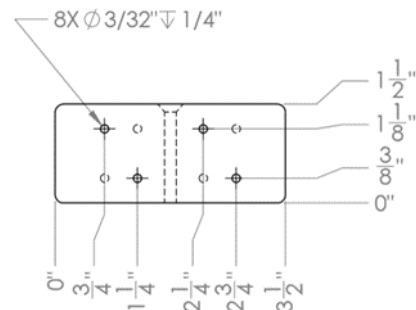

Figure 9: 2"x4" link side view



## 1.2. Partial assembling

### Required material

- (224x) 2" #8 countersunk head wood screws
- (42x) 2"x2" pre-drilled links
- (14x) 2"x4" pre-drilled links
- (28x) Continuity segments
- (4x) Rail #1
- (2x) Internal rails #2
- (2x) External rails #2
- (4x) Rail #3
- (2x) Internal rail #4
- (2x) External rail #4
- (4x) Rail #5
- (2x) Internal rail #6
- (2x) External rail #6
- (4x) Rail #7
- Drill
- S2 bit

### Straight sections assembly

- For each pair of straight rails, assemble as shown below.
  - A pair of #1 rails has additional holes to assemble the power wires, assemble these two rails together.
  - **IMPORTANT:** The "X's" on the links must all face-up.
- Do not completely tighten the screws yet.

Table 1: Naming of the straight rails' components

No.	Description	Qty.
1	Rail #1	4
2	Rail #3	4
3	Rail #5	4
4	Rail #7	4
5	Continuity segment	16
6	2"x4" pre-drilled link	8
7	2"x2" pre-drilled link	6
8	2"x2" pre-drilled link with fixation holes	2
9	2" countersunk head wood screws	64





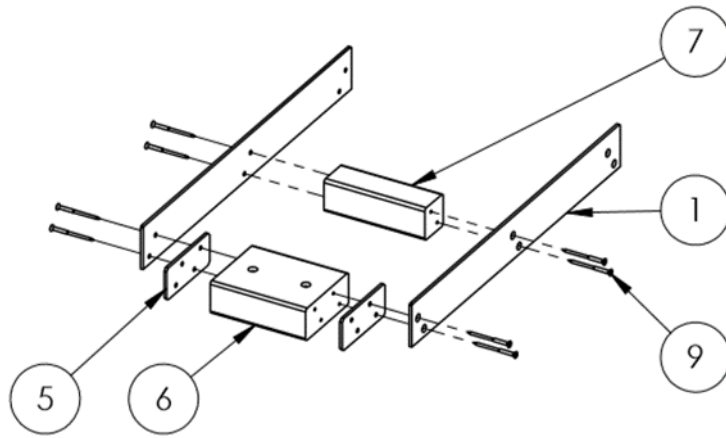

Figure 10: Section assembly #1

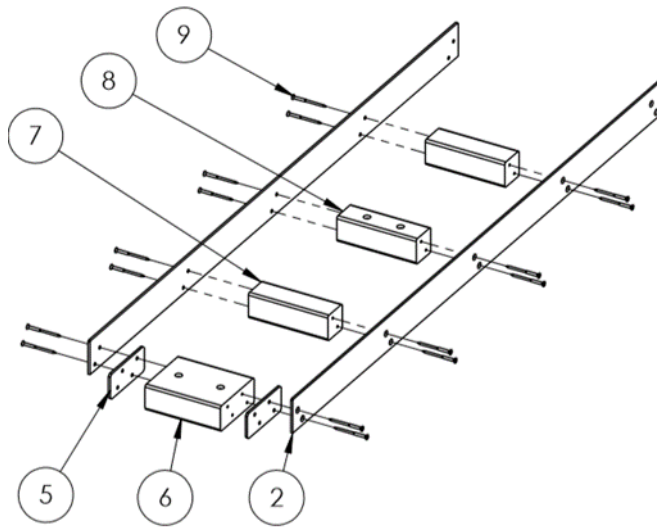

Figure 11: Section assembly #3

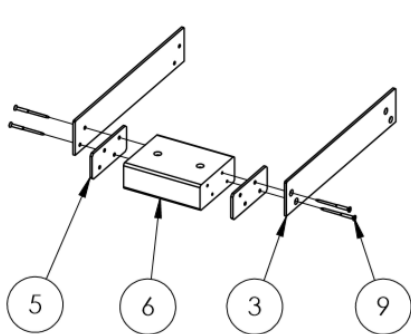

Figure 12: Section assembly #5

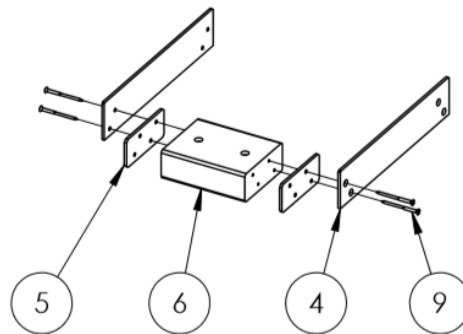

Figure 13: Section assembly #7



## Curved sections assembly

- For each pair of curved rails, assemble as below.
  - **IMPORTANT:** The "X's" on the links must all face-up.
- Do not completely tighten the screws yet.

Table 2: Naming of the curved rails' components

No.	Description	Qty.
1	Internal rail #2	2
2	External rail #3	2
3	Internal rail #4	2
4	External rail #4	2
5	Internal rail #6	2
6	External rail #6	2
7	Continuity segment	12
8	2"x2" pre-drilled link	30
9	2"x2" pre-drilled link with fixation holes	4
10	2"x4" pre-drilled link	6
11	2" #8 countersunk head wood screws	80

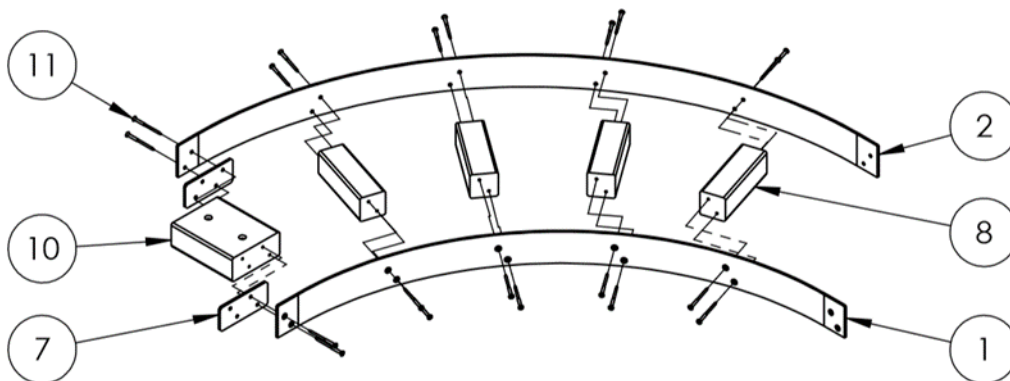

Figure 14: Section assembly #2



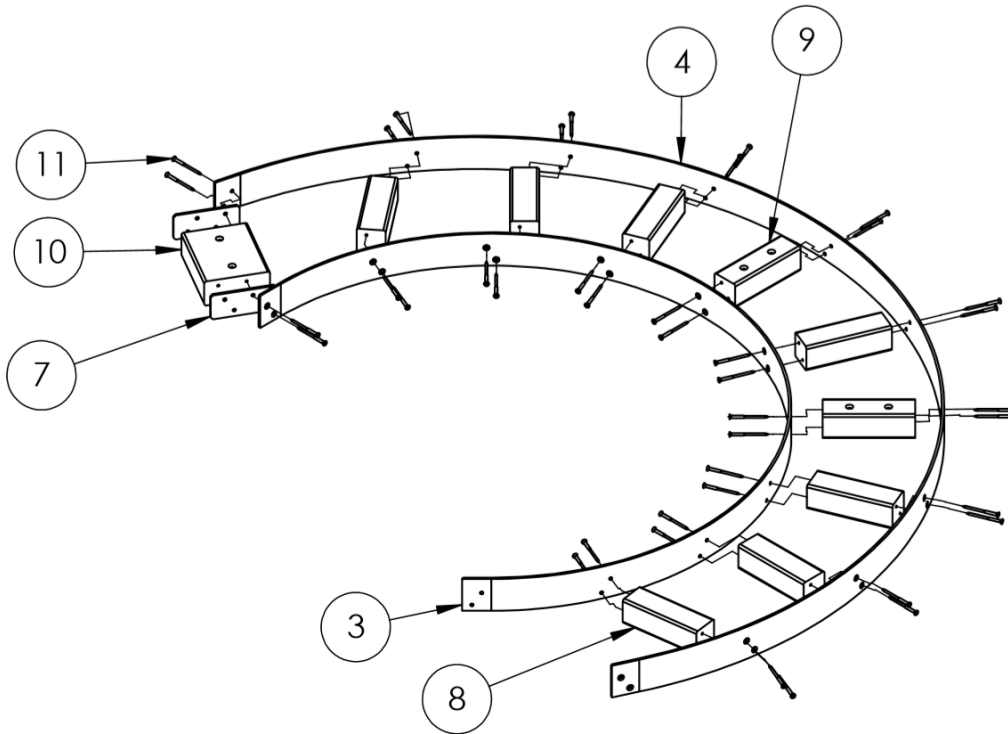

Figure 15: Section assembly #4

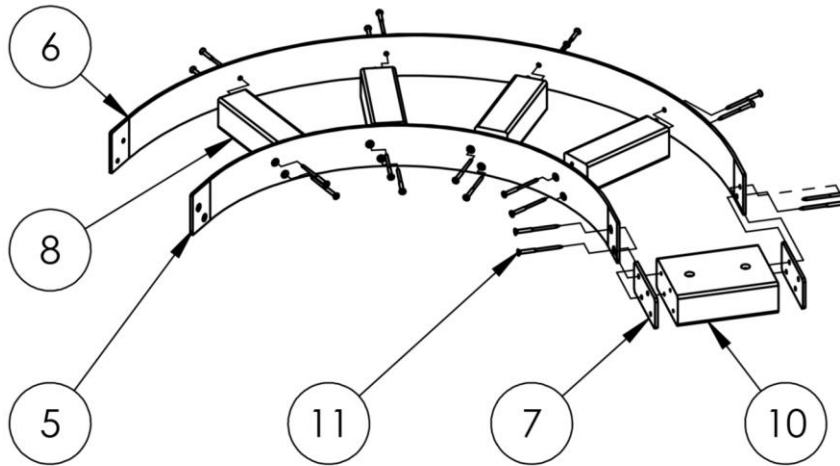

Figure 16: Section assembly #6



## 2. Course

### 2.1. Building the platform

#### Required material

- (3x) 3-1/2" 1/4-20 hex head screw
- (3x) 1/4-20 nut
- (6x) 1/4-20 washer
- (28x) 3" #8 countersunk head wood screws
- Drill
- (52x) 2" #8 countersunk head wood screws
- (2x) 3/4"x4'x8' plywood
- (11x) 2"x2"x8' spruce
- Miter saw
- 5/32" drill bit
- 5/16" drill bit
- 1/2" drill bit
- 7/16" wrench
- Pencil
- Measuring tape
- S2 bit

#### Frame cut-outs

- Select the 4 straightest 2"x2"x8' full lengths and set them aside.
- Among the rest, cut using a miter saw 14 lengths of 2"x2"x48" minus the thickness of two of the 2"x2"x48' (about 45").

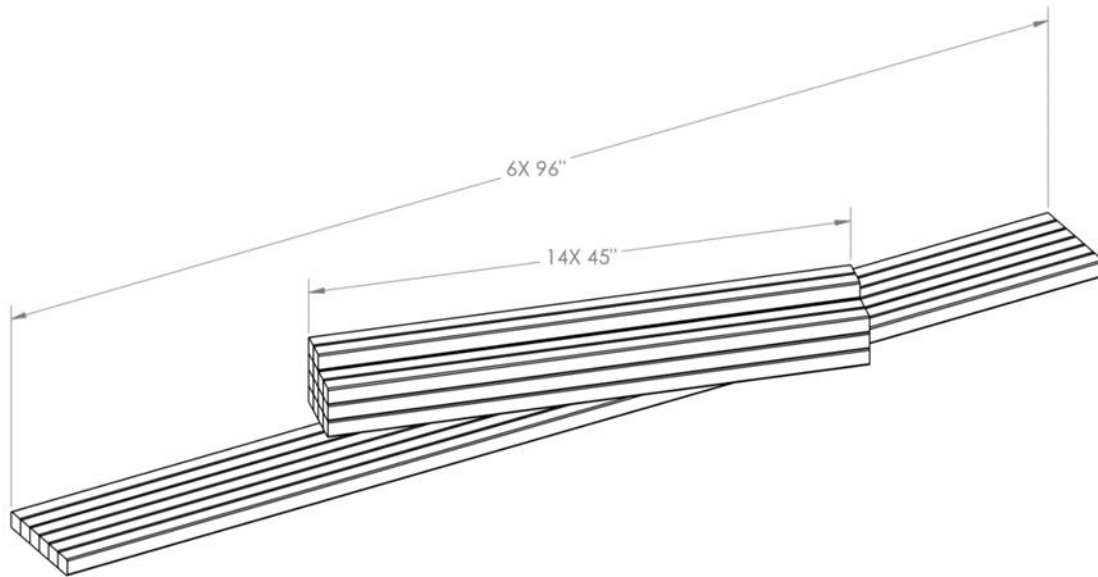

Figure 17: Frame cut-out lengths



## Frame assembly

- On one of the surfaces of the 8' lengths, draw 7 marks every 15-3/4" starting at 3/4".

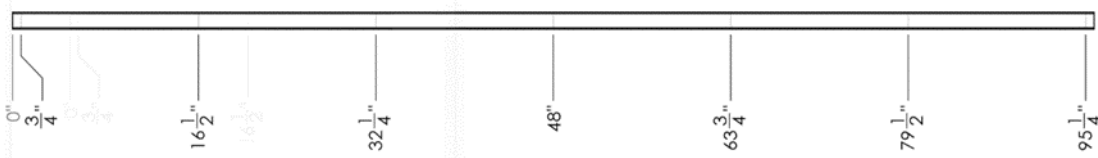

Figure 18: 2"x2"x8' markings

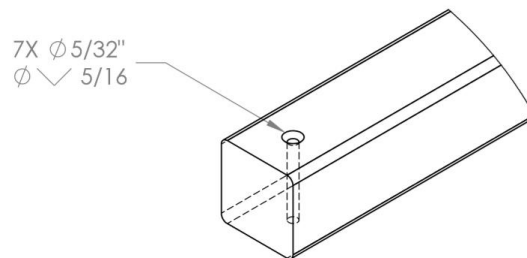
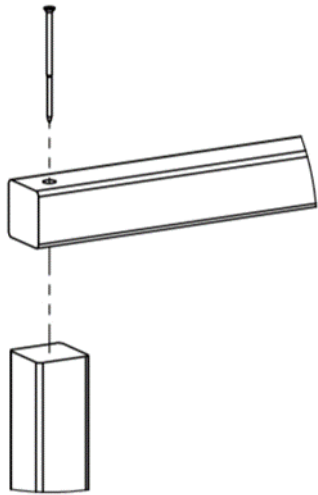

Figure 19: 2"x2"x8' drilling

- Drill a hole with a 5/32" drill bit through the 8' lengths aligned with the center of the marks.
  - Optionally use a drill bit with an integrated chamfering cutter.
- On the opposite side of the drilled chamfers, draw 6 marks at every 15-3/4" starting at 15-3/4".
- Form a frame using 2 of the 8' lengths and 2 of the 45" lengths.
- Evaluate perpendicularity by measuring an identical distance for both opposite corners. A difference of 1/2" between the two measures is acceptable.
- Screw the frame using the 3" screws.
  - If necessary, use clamps to keep the pieces flat on a work surface.





DETAIL A

Figure 20: Detailed view of frame screwing

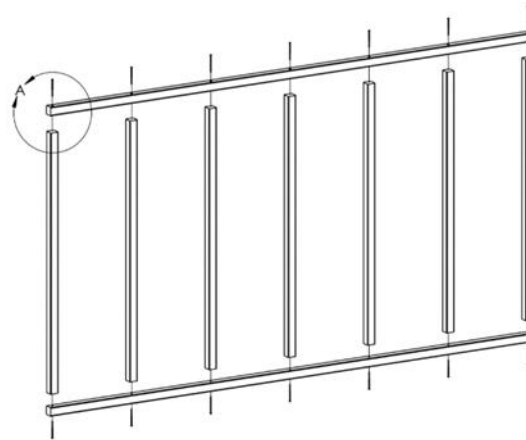

Figure 21: Frame screwing

- Screw the 5 reinforcements with 3" screws according to the previously made marks.
- Repeat a second time to obtain a second identical frame.
  - **Warning:** the frame is frail and should only withstand slight effort.



## Union bolts assembly and drilling of wires clearance holes

- Place the two frames side by side along their length. Make sure that the two adjacent 2"x2" are well supported and at the same height.
- At about 8" from each end and 45" near the center, drill 5/16" holes through the two 2"x2" spruces.

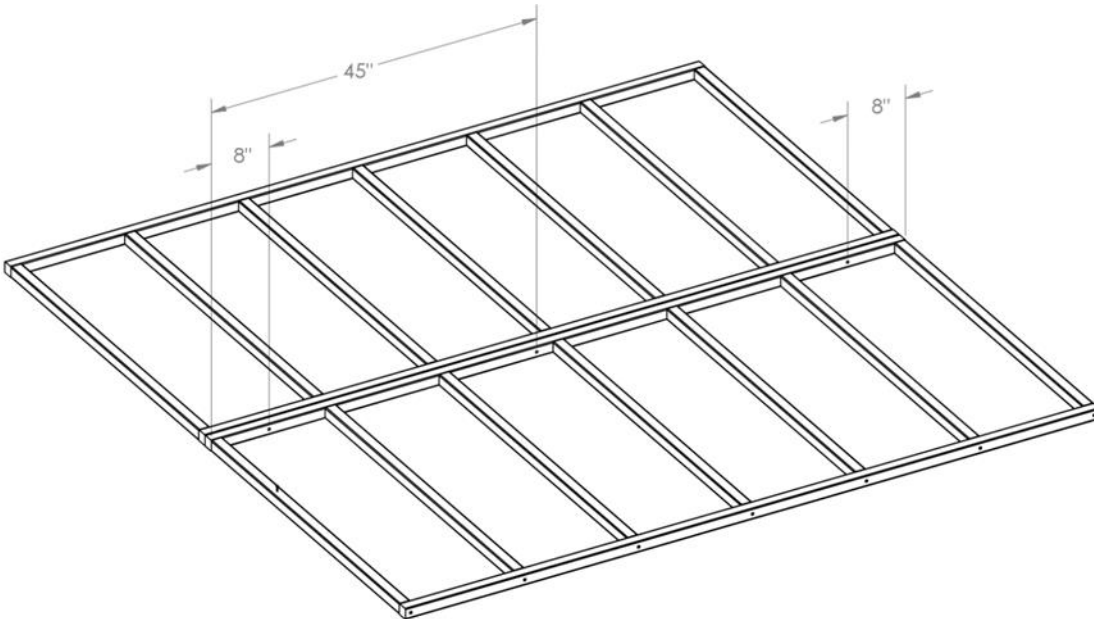

Figure 22: Union bolts' hole drilling

- Assemble and tighten the 1/4"-20 bolts as shown below.

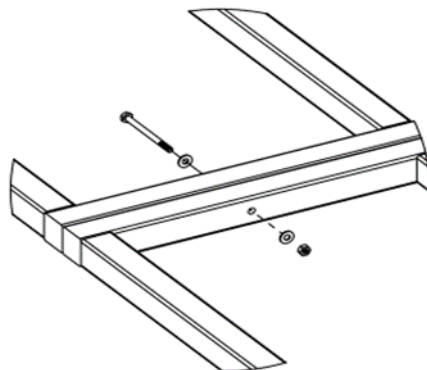

Figure 23: Assembling the union bolts





- Drill the holes as shown below with a 1/2" drill bit.

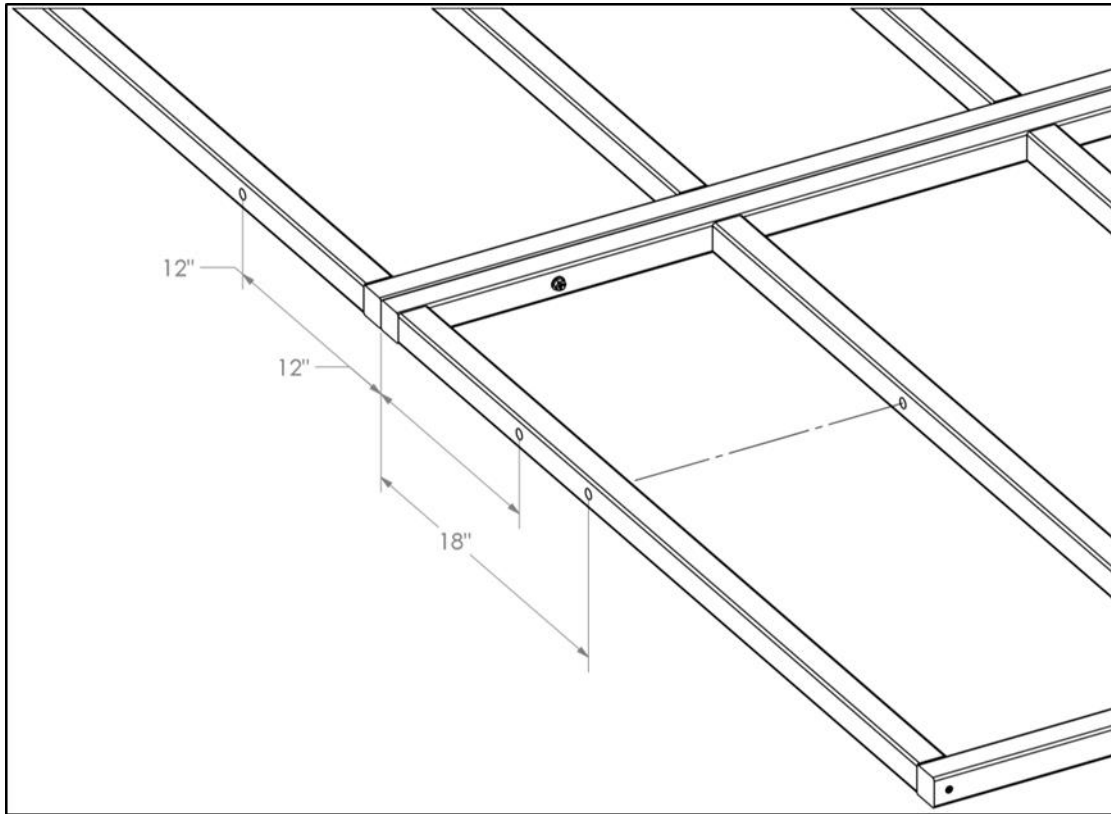

Figure 24: Drilling the wire run-through holes



## Plywood screwing

- Draw 5 lines every  $15\frac{3}{4}$ " starting at  $16\frac{1}{2}$ " on the plywood to locate the frame reinforcements

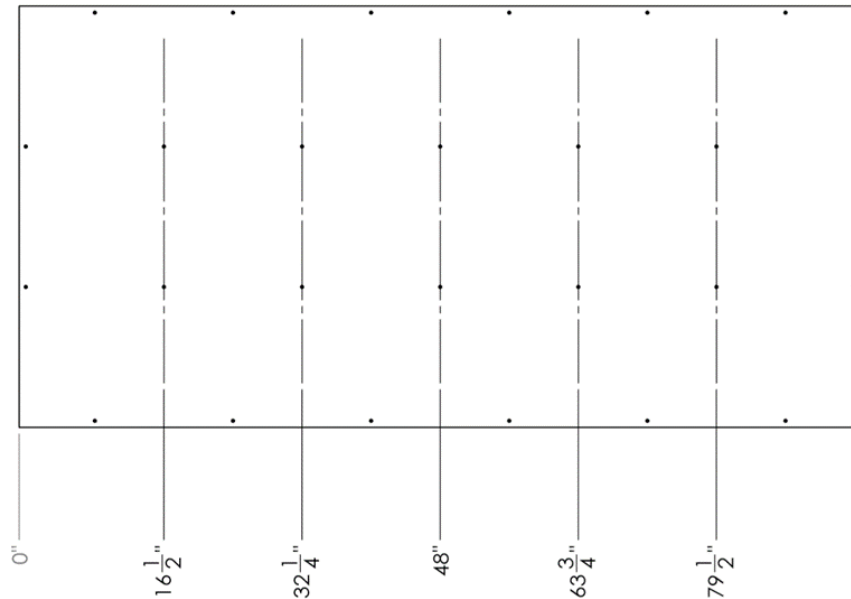

Figure 25: Marking the position of the frame reinforcements

- Lay both frames flat on the ground and place the two plywood sheets on top with marks facing upwards. Firmly press the two plywood sheets together to minimize the gap.
- Screw the plywood onto the frame as shown.
  - Straighten the frame while screwing it so that it takes the shape of the plywood.

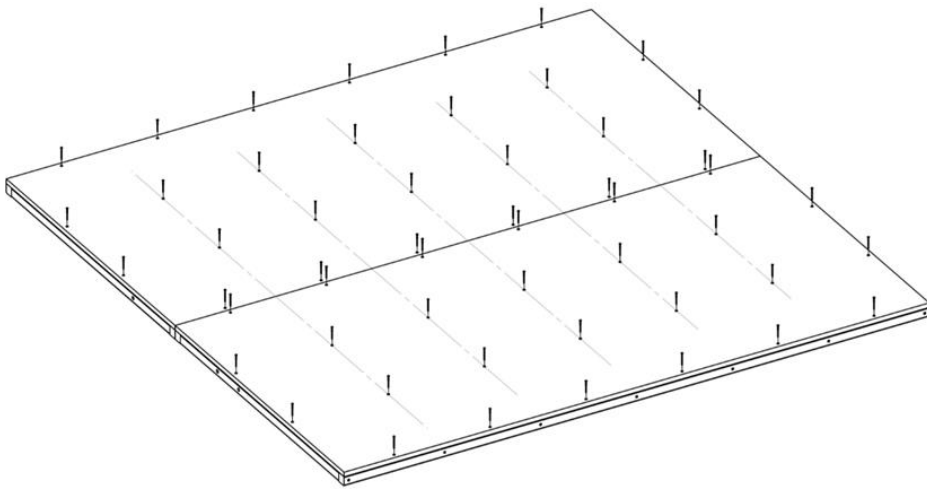

Figure 26: Screwing the plywood onto the frame



## 2.2. Tracing the positioning

### Required material

- Pencil
- Measuring tape

### Marking

- Delete existing lines on the plywood.
- On the assembled platform, draw the lines shown on the following drawings.
  - For more accuracy, draw two marks at the ends and connect them with a straight ruler.
  - An accuracy of  $\pm 1/8$ " is sufficient for the marking.

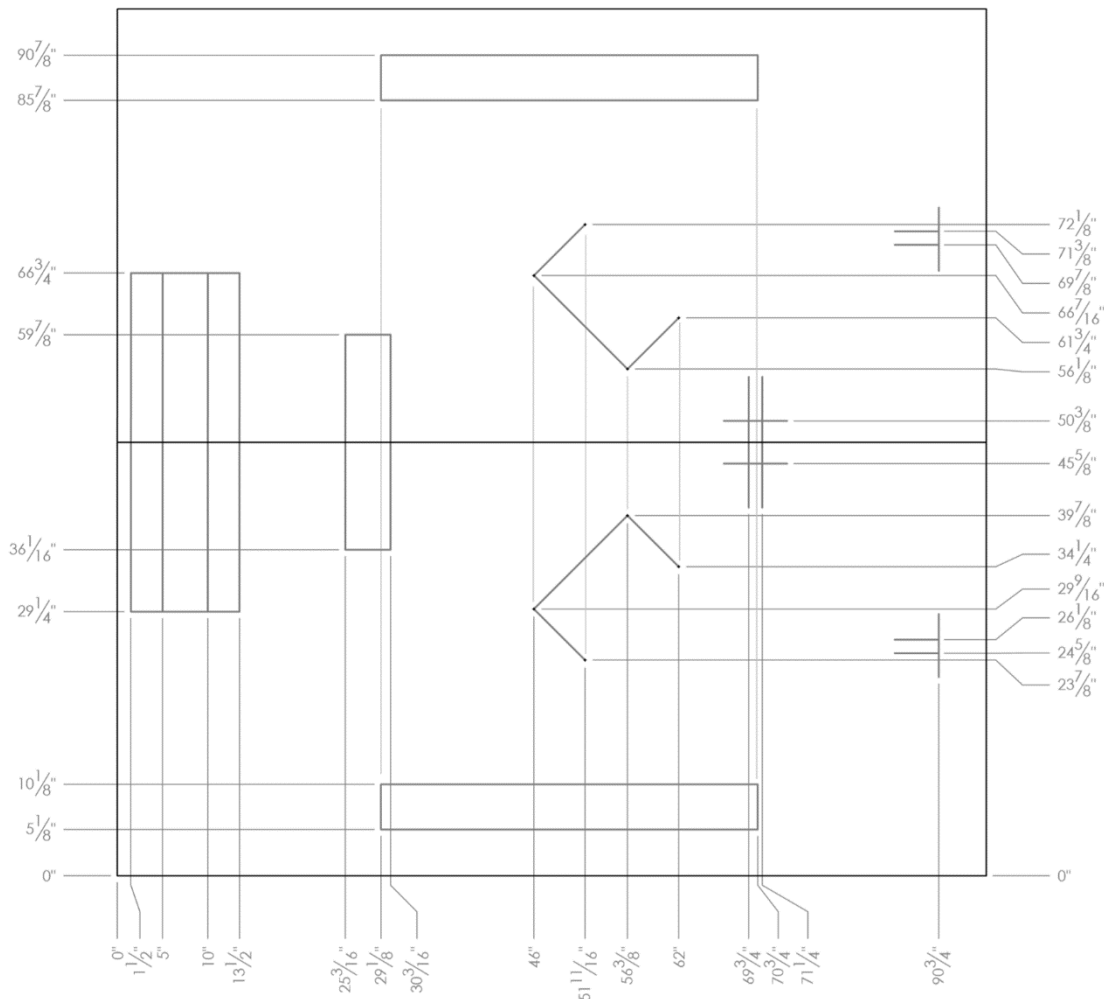

Figure 27: Marking the tracks' position



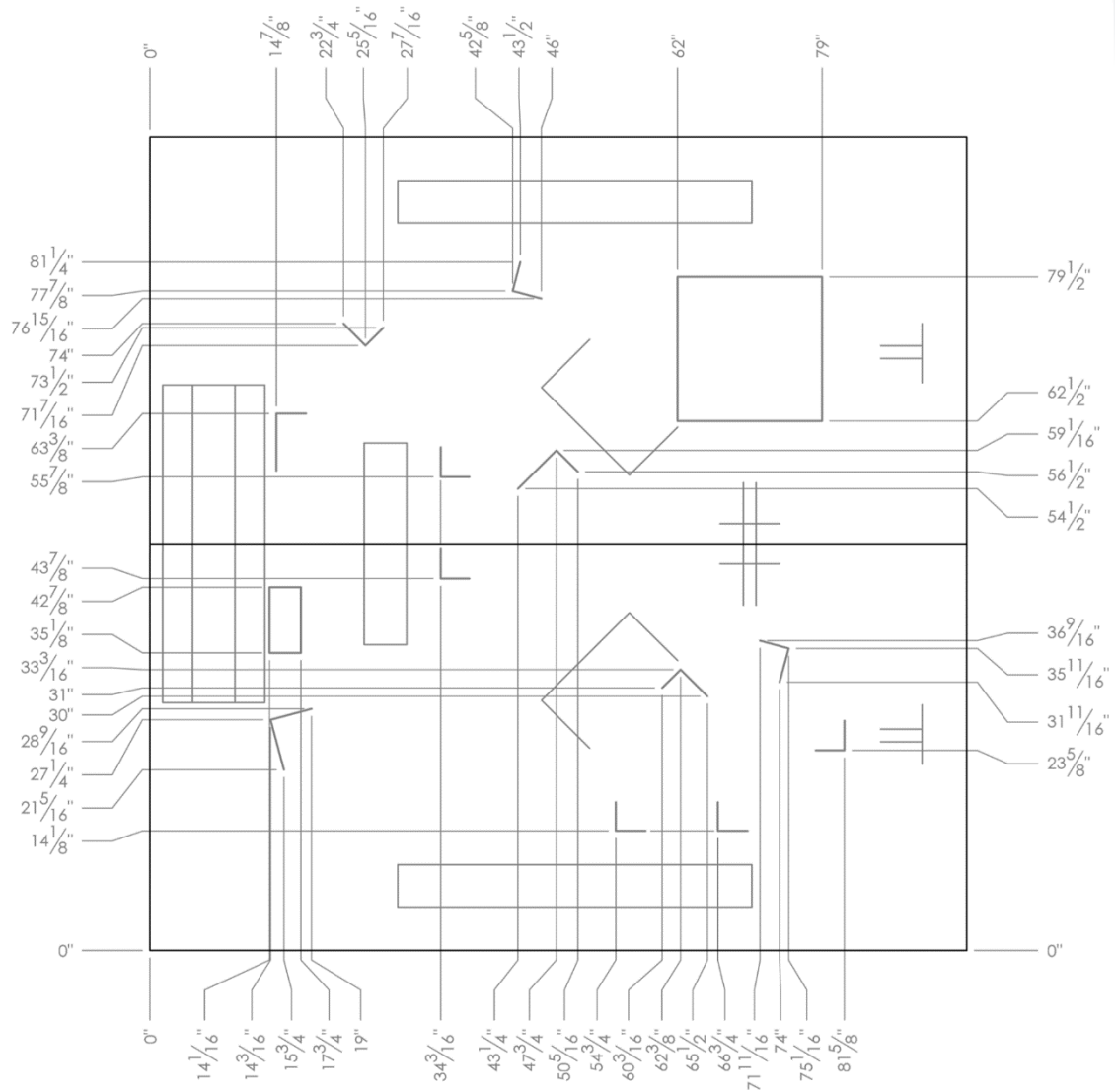

Figure 28: Marking the challenge elements' position



## 3. Challenge components

### 3.1. Packaging station

#### Required material

- (8x) 3" #8 countersunk head wood screws
- (1x) 2"x2"x8' spruce
- Drill
- Miter saw
- S2 bit
- 1/8" drill bit
- Measuring tape
- Optional: chamfer bit

#### Cutting

- Cut 4 pieces of the small and long lengths according to the drawings below.

#### Assembly

- Pre-drill angled holes on the small pieces.
- Assemble the 8 pieces with the 3" screws.
  - If necessary, use clamps to keep the pieces flat on a work surface.



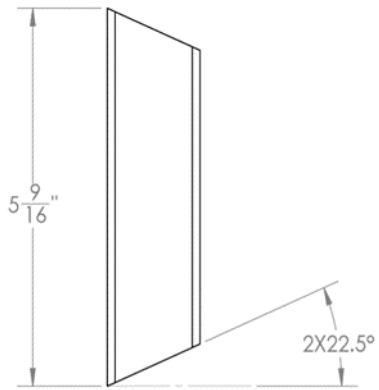

Figure 29: Small piece top view

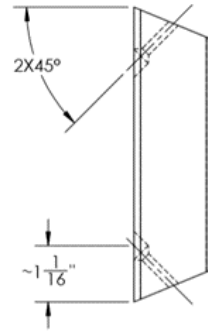

Figure 31: Small piece drilling location

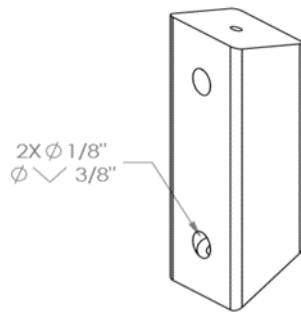

Figure 30: Small piece isometric view

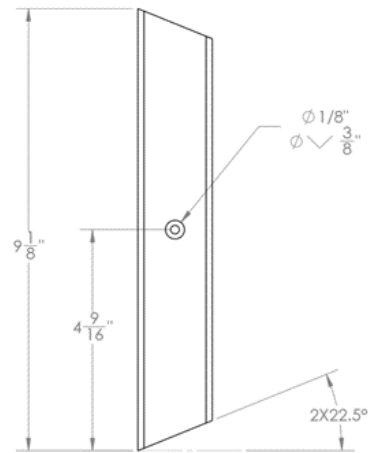

Figure 32: Big piece top view

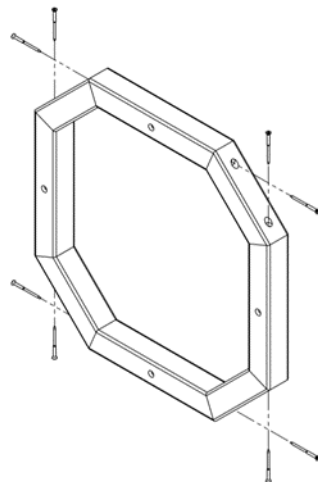

Figure 33: Assembly's isometric view



## 3.2. Making the trays

### Required material

- (1x) 2'x4'x3/4" MDF
- (1x) 2'x4'x1/4" MDF
- Carpenter glue
- Clamps
- Pencil
- Press drill
- Miter saw
- Saw bench
- 1/8" drill bit
- Measuring tape
- 11/16" drill bit OR 5/8" drill bit (Forstner bit or spade drill bit)

### Cutting

- Cut 2 strips of 3-1/4" out of the 3/4" MDF sheet on its long side.
  - Optionally, without a saw bench, cut the short side 5 times on two opposite directions (normally a miter saw can cover a little more than 1' per cut).
- Using the miter saw, cut the 3/4" MDF strips into 25 pieces of 3-1/4".
- Cut 2 strips of 2-1/2" out of the 1/4" MDF sheet on its long side.
  - Optionally, without saw bench, cut the short side 4 times in the on the two opposite directions.
- Using the miter saw, cut the 1/4" MDF strips into 25 pieces of 2-1/2".

### Drilling

- On the 25 pieces of MDF 3/4", draw the center of the holes.
- Pre-drill on the marks using a 1/8" drill bit on a column drill.
- Drill in the guide holes with a 11/16" drill bit.
  - **You can use a 5/8" drill bit for an almost equivalent result.**

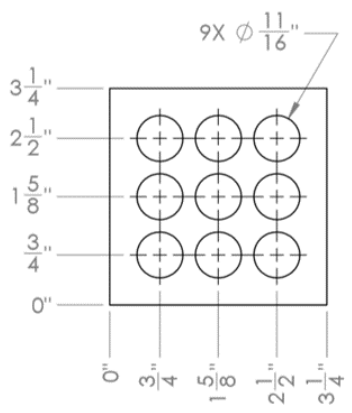

Figure 34: 3/4" MDF drawing

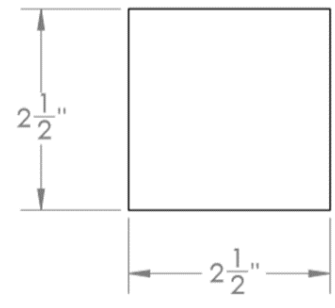

Figure 35: 1/4" MDF drawing





## Gluing

- Spread glue on one of the two surfaces of a 1/4" MDF square.
- Position a 1/4" MDF square to cover one end of the holes of a 3/4" MDF square as shown below.
- Tighten the two parts together with a clamp and leave them sit for eight hours.
- Repeat for the other 24 square pairs.

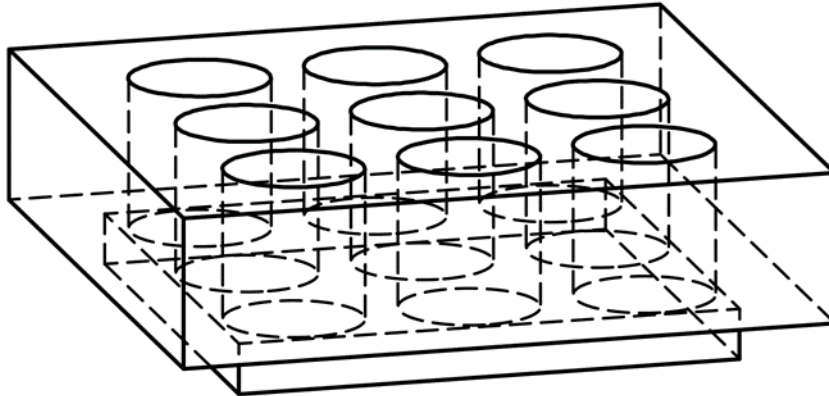

Figure 36: Tray isometric view

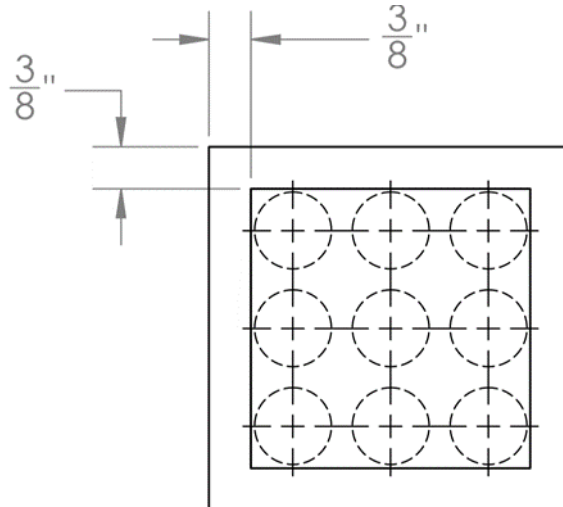

Figure 37: Relative position of each parts



### 3.3. Tray baseplates

#### Required material

- (1x) 2"x4"x8' spruce (39" required)
- Miter saw
- 1/8" drill bit
- Measuring tape
- Optional: chamfer bit

#### Fabrication

- Cut out 11 pieces of 3-1/2" out of the 2"x4" spruces.
- Drill and chamfer (optionally) two 1/8" holes for mounting as shown in the below drawing. Location is not important.

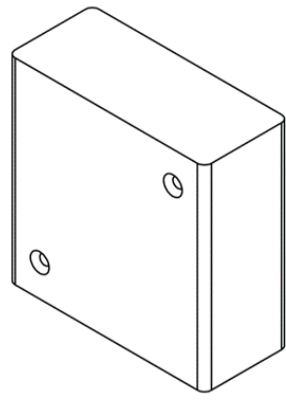

Figure 38: Baseplate isometric view

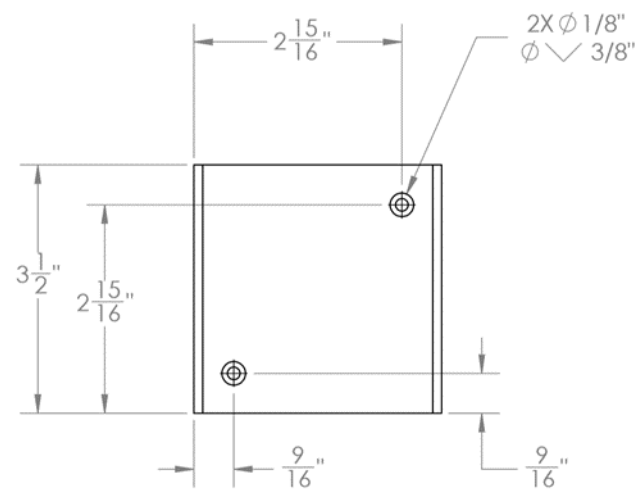

Figure 39: Baseplate hole position



## 3.4. Dispenser

### Required material

- (4x) 2" #8 countersunk head wood screws
- (1x) 2"x4"x8' spruce (10½" required)
- Miter saw
- 1/8" drill bit
- 3/32" drill bit
- Drill
- S2 bit
- Measuring tape
- Optional: chamfer bit

### Fabrication

- Cut 1 piece of 6-¾" out of the 2"x4" spruce.
- Cut 1 piece of 3-¾" out of the 2"x4" spruce.
- Drill the 1/8" holes as shown below.
  - Location is not important.
  - Chamfers are optional.
- Screw the small piece onto the large one. Firmly tighten the screws to prevent the head from protruding.
- Pre-drill the 3/32" holes with the dispenser in place.
- Screw on the dispenser.

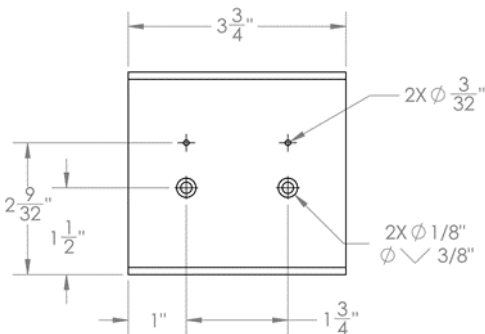

Figure 40: Small piece drilling

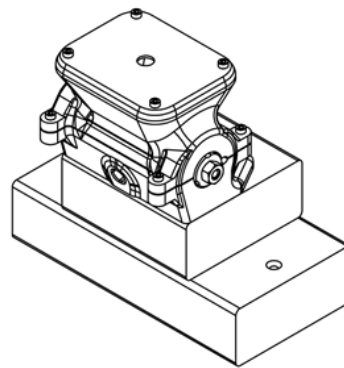

Figure 41: Assembly isometric view



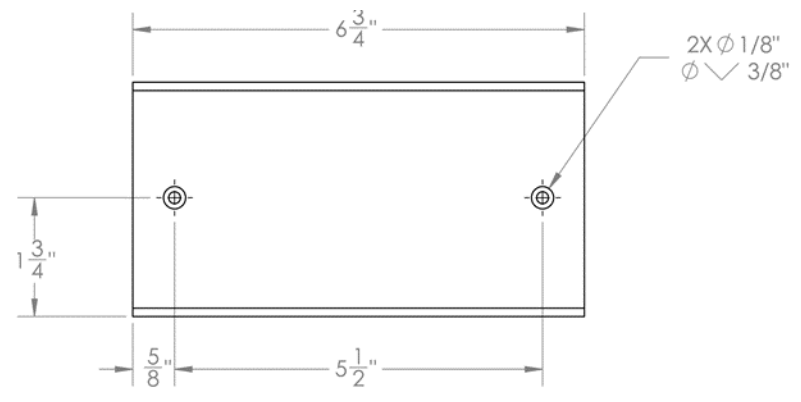

Figure 42: Big piece drilling

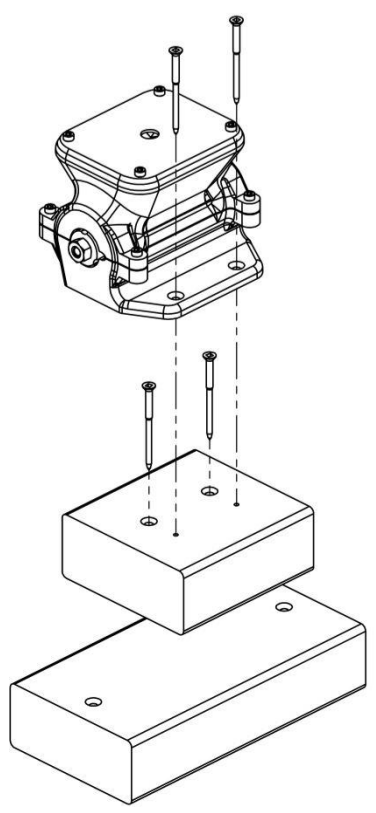

Figure 43: Assembly exploded view



# 4. Final assembly

## 4.1. Rail installation

### Required material

- (92x) 2" #8 countersunk head wood screws
- (2x) Preassembled sections #1
- (2x) Preassembled sections #2
- (2x) Preassembled sections #3
- (2x) Preassembled sections #4
- (2x) Preassembled sections #5
- (2x) Preassembled sections #6
- (2x) Preassembled sections #7
- Assembled course
- Drill
- S2 bit

### Assembly

- Flat on the ground, pre-assemble all sections together, without tightening the screws.

Table 3: Naming of the track assembly components

No.	Description	Qty.
1	Preassembled section #1	2
2	Preassembled section #2	2
3	Preassembled section #3	2
4	Preassembled section #4	2
5	Preassembled section #5	2
6	Preassembled section #6	2
7	Preassembled section #7	2
8	2" #8 countersunk head wood screws	56



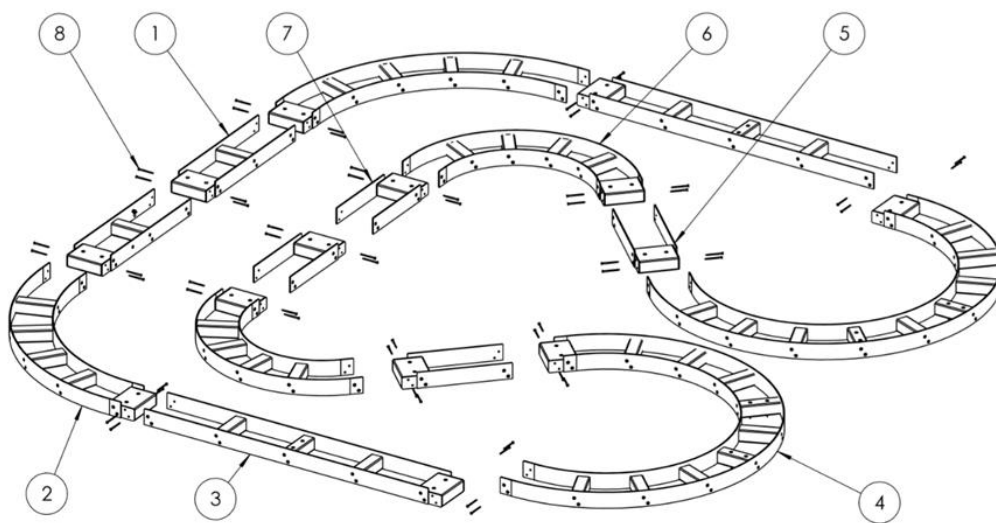

Figure 44: Tracks assembly exploded view

- Position the flexible assembly starting by the #1 sections using the course marks.
- Screw-in both sections.
- Repeat for #7, #3, #4 and #5 sections in this order.
  - For the last sections, you will possibly need to use more force.
- Gradually tighten all link screws starting from the #1 sections.
  - **IMPORTANT:** Tighten **gradually** to avoid deforming the rails.

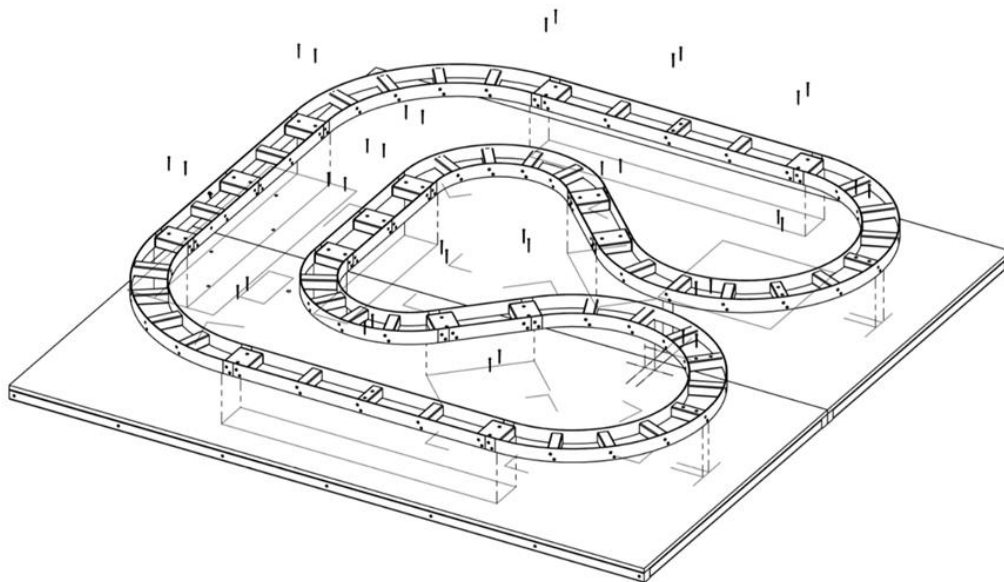

Figure 45: Track position on the course



## 4.2. Installing the challenge components

### Required material

- (32x) 2" #8 countersunk head wood screws
- Assembled distributor
- Drill
- (11x) Tray base
- Generator
- (4x) Generator support
- (1x) Packaging station
- Assembled course with tracks
- S2 bit

### Assembly

- Screw the elements onto the marks in the course as shown per the below drawings.

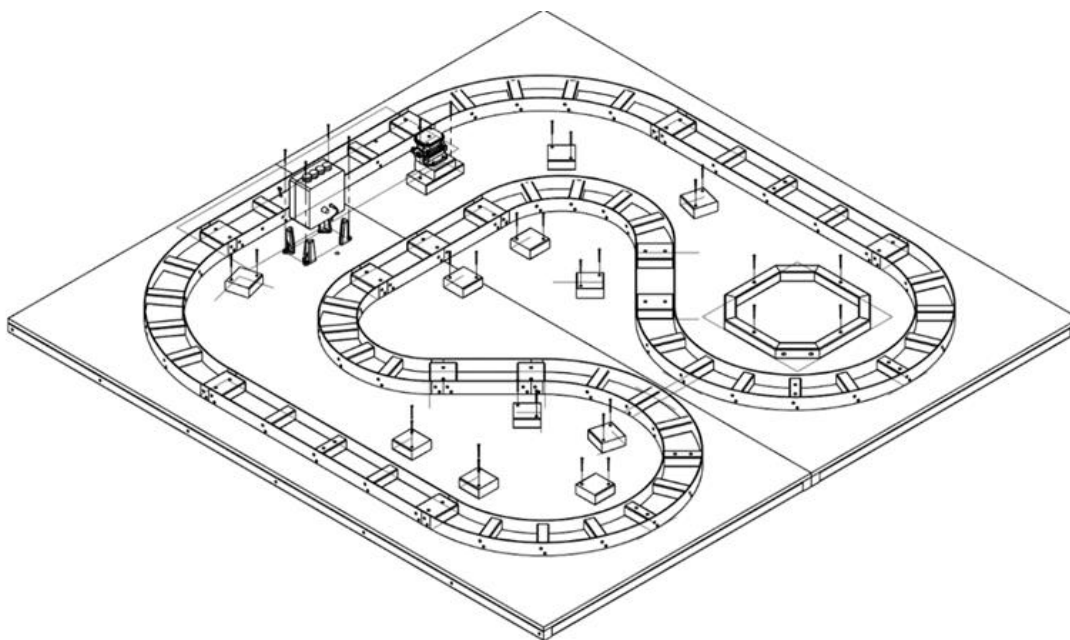

Figure 46: Challenge components position on the course





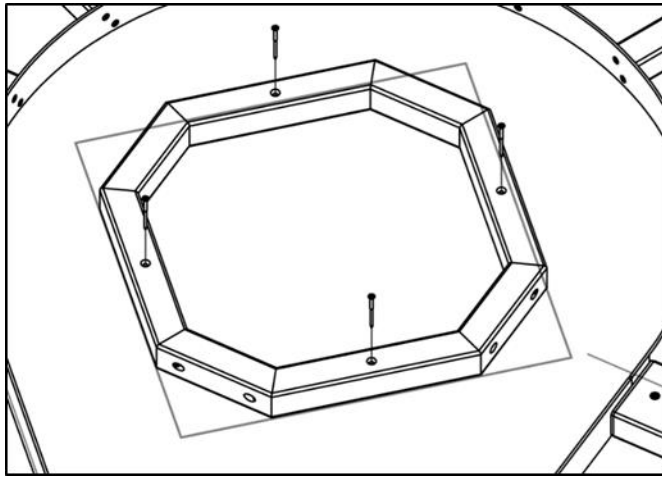

Figure 47: Packaging station assembly on its marks

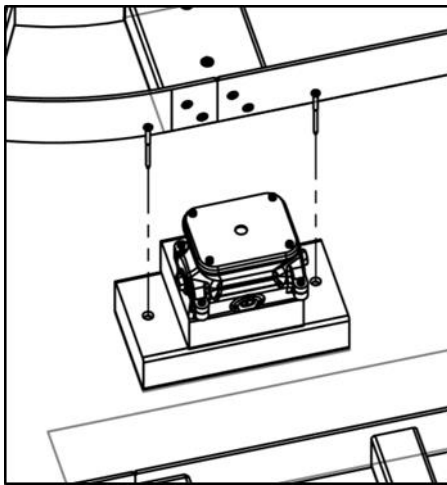

Figure 48: Distributor assembly on its marks

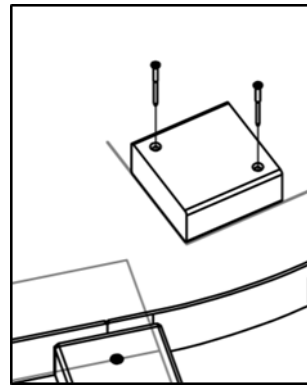

Figure 49: Tray baseplate on its marks

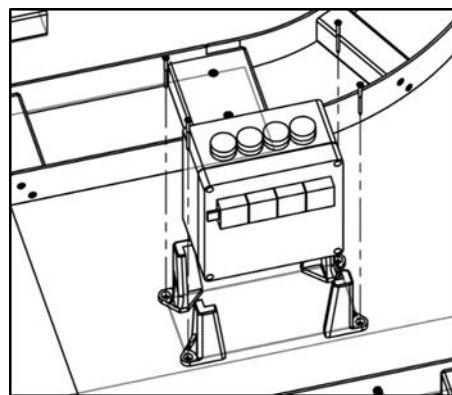

Figure 50: Generator assembly on its marks



## 4.3. Electrical power supply

### Required material

- (2x) #8 countersunk head screw
- (4x) #8 nut
- (2x) #8 washer
- Drill
- 1/2" drill bit
- 11/32" wrench
- S2 bit screwdriver

### Drilling for wire clearance holes

- According to the electric connection holes on the #1 rail, drill a hole of 1/2" through the platform inside the rails.
- Behind the generator, facing its power connector, drill a hole of 1/2" close to the generator. If necessary, mark the position and remove the generator before drilling.

### Connector assembly

- Assemble both connexions as shown below.

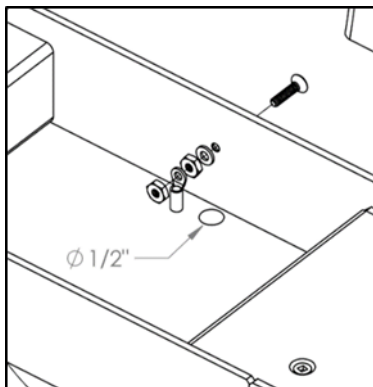

Figure 51: Connector assembly and tracks power supply wire holes

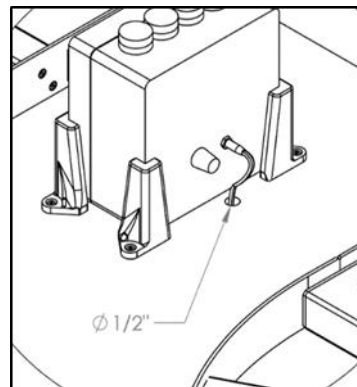

Figure 52: Generator power supply wire hole

